

RoHS  
Compliant

HF

SERIES SFF-8639 RECEPTACLE CONNECTOR

REV.	ECN.NO.	MODIFY.CONTENT
X1	2023-05-12	NEW

NOTES:

- MATERIAL:  
HOUSING: HIGH TEMPERATURE THERMOPLASTIC 94V-0, BLACK COLOR  
CAP : HIGE THERMOPLASTIC, UL94V-0,BLACK.  
TERMINAL: COPPER ALLOY  
BOARD LOCK : COPPER ALLOY  
GROUND SHRAPNEL: HIGH TEMPERATURE ELECTROPLATED PLASTIC
- PLATING:  
TERMINAL: SELECTIVE Au (SEE ORDER INFORMATION) ON CONTACT AREA,  
MATTE TIN ON SOLDER TAIL 80u"AREA, BOTH OVER Ni 50u" UNDERPLATED.  
BOARD LOCK:  
MATTE TIN ON SOLDER TAIL 80u"AREA, BOTH OVER Ni 50u" UNDERPLATED.
- MECHANICAL PERFORMANCE  
INSERTION FORCE: 59N MAX  
WITHDRAWAL FORCE: 6N MIN  
DURABILITY: 500 CYCLES
- ELECTRICAL PERFORMANCE  
CURRENT RATING: 1.5A MIN  
CONTACT:INITIAL 30mΩ MAX. FINAL 45 mΩ MAX  
INSULATION RESISTANCE:1000MΩ MIN. AT 500V DC  
DIELECTRIC WITHSTAND VOLTAGE: AC 500V FOR 1 MINUTE.
- SUPPORT PCIe GEN5
- THE FOLLOWING PINS IS SHORT CIRCUIT BY THE ELECTROPLATED PLASTIC  
S1,S4,S7 SHORT CIRCUIT BY THE ELECTROPLATED PLASTIC.  
E9,E12,E15,S8,S11,S14,S16,S19,S22,S25,S28,E19,E22.  
SHORT CIRCUIT BY THE ELECTROPLATED PLASTIC.
- ORDER INFORMATION: PSA04-FL68-00XX

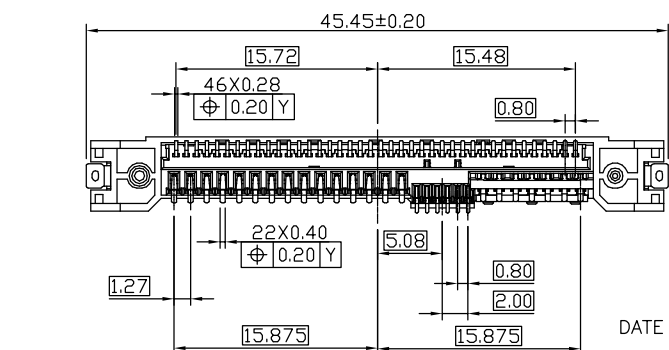
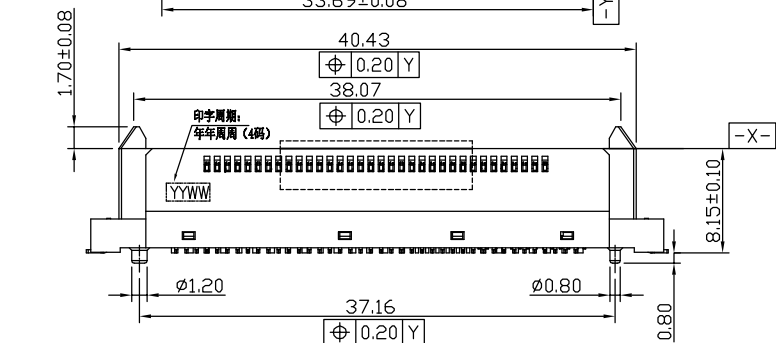
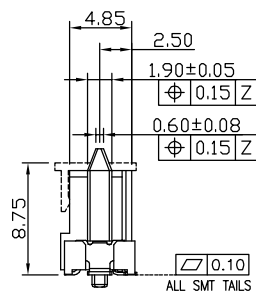
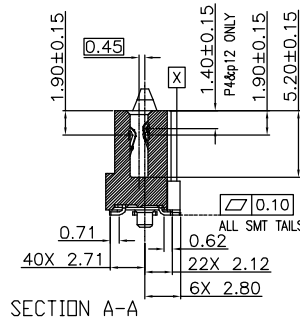
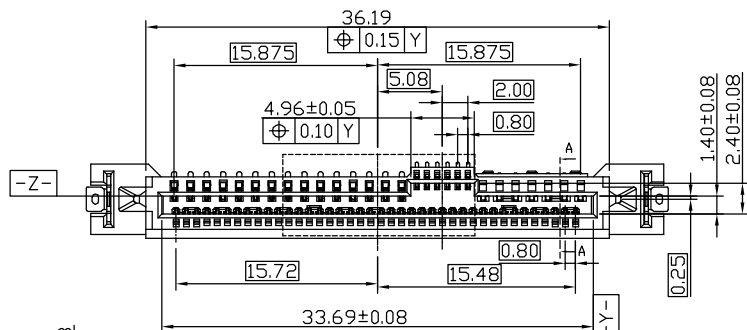

DATE CODE: YY WW D  
DAY  
WEEK  
YEAR

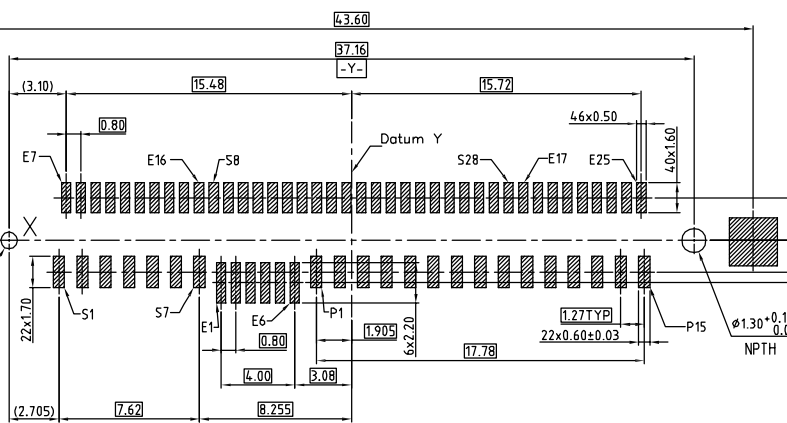

- 42: Au 1u"
- 43: Au 3u"
- 46: Au 15u"
- 47: Au 30u"

RECOMMENDED PCB LAYOUT (TOP VIEW)  
GENERAL TOLERANCE ±0.05(PCB THICKNESS:1.0~2.0mm)

CAP DIMENSION

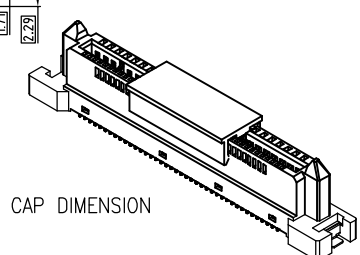

GENERAL TOLERANCE	DWG.NO.	PSA04-FL68-0000	PART.NO.	PSA04-FL68-00XX	DRAWN	Tony 2023-05-12	UNIT	mm	SCALE	1:1
x.±0.50	REV.	X1	TITLE	PCIe5.0 VERTICAL SMT CONN	CHECKED		东莞市欧联电子科技有限公司 DONGGUAN OLN ELECTRONICS TECHNOLOGY CO., LTD.			
.x±0.25	SIZE	A4	SHEET	1 OF 2	APPROVED					
.xx±0.15	A4									

RoHS  
Compliant

HF

# 东莞市欧联电子科技有限公司

## 包装作业规范

REV.	ECN.NO.	MODIFY.CONTENT
X1	2023-05-12	NEW

### 包装作业图示及说明 (PACKING OPERATION DIAGRAM & INSTRUCTION)

- 一. 1) 将成品一一放入REEL包装盘内,依同一方向放入.  
2) 包装时,如图所示.  
3) 一个REEL包装盘放置300个成品.

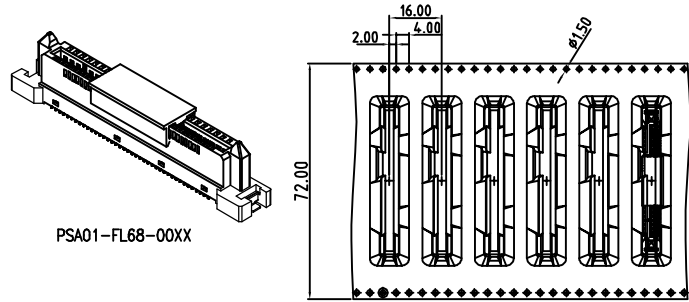

- 三. 1) 每箱装 4 盘REEL包装盘.  
2) 每箱放置1200 PCS 的成品.

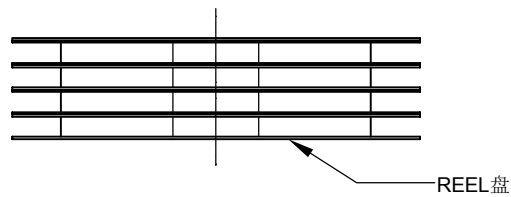

- 四. 1) 用TAPE將紙箱封實.

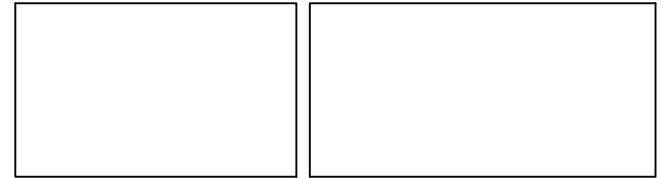

- 二. 1) 装盘前先把前面空15pcs产品,然后再开始装盘,尾端也需空15pcs产品,上带加长200mm.  
2) 装满成品的REEL包装盘如下图所示.

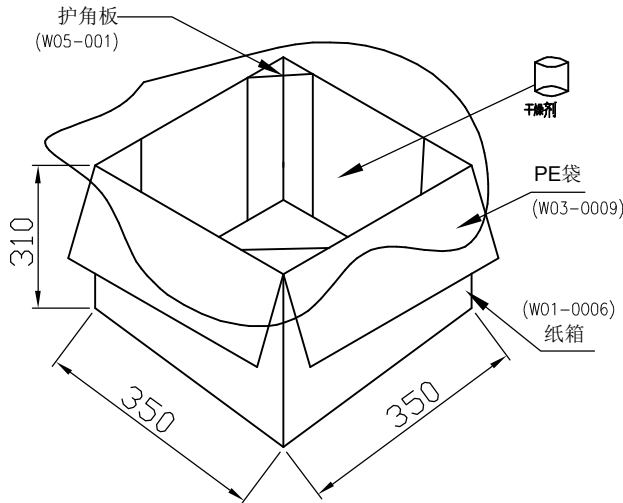
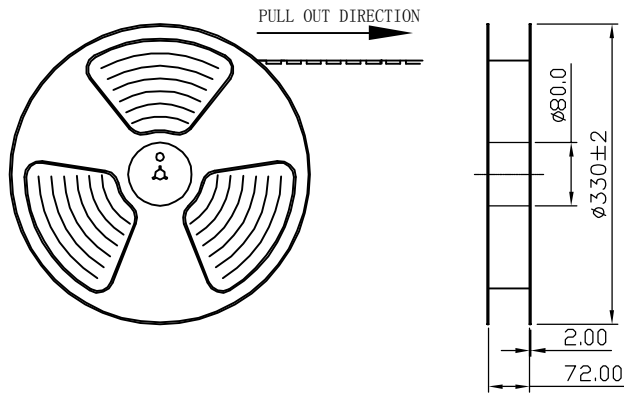

#### 備註 (REMARK)

1. 若有未裝滿之零數箱,必須以緩衝材塞滿.

GENERAL TOLERANCE	TOLERANCE	DWG.NO.	PART.NO.	PART.NO.	DRAWN
x,±0.50	x.± 5°	PSA04-FL68-0000	PSA04-FL68-00XX	Tony	2023-05-12
.x±0.25	.x.± 2°	REV.	TITLE		
.xx±0.15	.xx± 1°	SIZE	SHEET		
		A4	2 OF 2		

OLN®

东莞市欧联电子科技有限公司  
DONGGUAN OLN ELECTRONICS TECHNOLOGY CO., LTD.